

**6-Year Limited Tank Warranty/6-Year Parts Warranty\***

The PowerFlex® Power Vent water heaters have been engineered to maximize efficiency and deliver a greater energy factor (EF).

## FEATURES

### ENERGY STAR® Qualified

- All models meet the September 2010 ENERGY STAR® EF requirement and may also qualify for local utility and rebate programs
- Newly designed LimeFighter® dip tube optimizes inlet water pressure to minimize cold water regions within the tank. The self-cleaning action also reduces sediment accumulation on the bottom of the tank.
- Hot-surface ignitor is more robust and reliable than standing pilot, and reduces energy consumption
- Built-in heat traps on the water inlet and outlet reduce the amount of heat lost through piping
- 2-inch, thick, "Environmentally-Friendly" foam insulation reduces the amount of heat loss and contributes to overall energy efficiency

### Versatile Power Vent Design

- All models feature an **exclusive** 3-position rotatable blower outlet which adds flexibility
- Combined horizontal and vertical vent runs up to 180 equivalent feet with 4" diameter venting (ABS, PVC, CPVC and polypropylene)
- All models are equipped with a protected sensor that detects the presence of flammable vapors and automatically disables the burner to prevent ignition
- Air intake snorkel elevates the inlet location of combustion air to prevent flammable vapors from entering the sealed combustion chamber
- Reduced NOx emissions comply with air quality management district regulations

### User-Friendly:

- State-of-the-art electronic gas control provides more precise temperature control
- LED control light displays operation status and diagnostics information
- Factory-installed T&P and a durable, tamper-resistant brass drain valve are positioned for service accessibility

### Available in Natural Gas and Propane



\*For complete warranty information consult the written warranty of American Water Heaters found at [www.americanwaterheater.com](http://www.americanwaterheater.com), or call (800) 999-9515.

## POWERFLEX® POWER VENT

MODEL NUMBER	SERIES	HEIGHT TO TOP OF BLOWER A	HEIGHT TO TOP OF TANK B	DIAMETER C	OVERALL DEPTH D	HEIGHT TO DRAIN E	HEIGHT TO GAS INLET F	HEIGHT TO T&P G	HEIGHT TO UPPER SIDE CONNECT G	HEIGHT TO LOWER SIDE CONNECT H	SHIPPING WEIGHT LBS
PVG62-40S40-NVS	200	59	49-5/8	22	29-1/8	11	14-1/4	42-1/2	N/A	N/A	174
PVG62-40T50-NVS	200	68-1/2	59-1/4	20	27-1/8	11	14-1/4	53-1/8	53-1/8	15-1/4	176
PVG62-50S40-NVS	200	60-1/8	50-3/4	24	31-1/8	11	14-1/4	43-3/4	N/A	N/A	198
PVG62-50T50-NVS	200	68-1/8	58-3/4	22	29-1/8	11	14-1/4	51-3/4	51-3/4	15-1/4	192
PVG62-50S62-NVS	200	61-1/8	52	24	31-1/8	11	14-1/4	44-1/2	44-1/2	15-1/4	212
PVG62-75T72-NVS	200	70-5/8	61-1/4	26	33-1/8	11	14-1/4	53	53	15-1/4	277

All dimensions in inches.

Natural gas models cited are series 200. Propane models are series 201. For propane models, change the "NVS" to "PVS" in the model number.

All models rated for installation at altitudes up to 10,100 ft.

Side connections available on 40T50 and 50T50 models.

## SPECIFICATIONS

MODEL NUMBER	GALLON CAPACITY	INPUT BTU/H	ENERGY FACTOR	FIRST HOUR RATING USG	RECOVERY 90°F RISE GPH
PVG62-40S40-NVS	40	40,000	0.70	73	44.7
PVG62-40T50-NVS	40	50,000	0.70	90	55.9
PVG62-50S40-NVS	50	40,000	0.70	90	44.7
PVG62-50T50-NVS	50	50,000	0.70	96	55.9
PVG62-50S62-NVS	50	62,000	0.70	110	69.3
PVG62-75T72-NVS	75	72,000	0.68	155	80.4

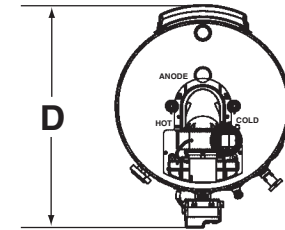

## VENT LENGTH

MODEL NUMBER	MAXIMUM VENT LENGTH EQ. FT.		
	Ø2"	Ø3"	Ø4"
PVG62-40S40-NVS	50'	125'	180'
PVG62-40T50-NVS	50'	125'	180'
PVG62-50S40-NVS	50'	125'	180'
PVG62-50T50-NVS	50'	125'	180'
PVG62-50S62-NVS	N/A	50'	125'
PVG62-75T72-NVS	N/A	50'	125'

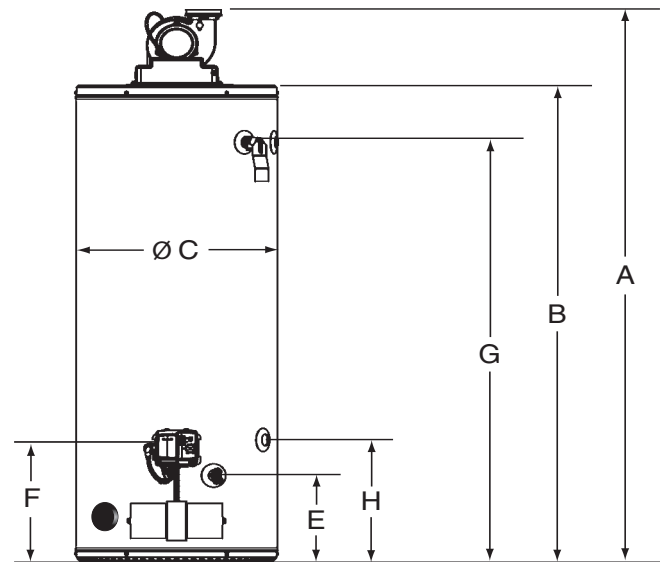

## Distributed By:

### Order Entry and Sales

500 Princeton Road (FEDEX, UPS)  
 Johnson City, TN 37601-2030  
 P.O. Box 4808 (Mailing)  
 Johnson City, TN 37602-4808  
 (800) 937-1037  
 FAX (800) 581-7224

### Warranty and Service

500 Princeton Road (FEDEX, UPS)  
 Johnson City, TN 37601-2030  
 P.O. Box 1597 (Mailing)  
 Johnson City, TN 37605-1597  
 (800) 999-9515  
 FAX (800) 999-5210